

Supercal 739

Compact Thermal Energy Meter

Single-Jet Meter



Coaxial Multi-Jet Meter
with G 2" thread



Coaxial Multi-Jet Meter
with M77x1.5 thread



Application

The **Supercal 739** is an autonomous compact thermal energy meter consisting of a flow meter an integrator and a pair of temperature sensors. It's used in home automation, local and district heating/cooling systems to measure the consumption of heating or cooling energy for the individual heat cost billing. It's made to measure lower flows and energies. The compact thermal energy meter **Supercal 739** meets the requirements of the European guideline MID-2004/22/EC and the standard EN 1434.

The compact heat meter **Supercal 739** is available as a single-jet meter and as coaxial multi-jet meters (G2" or M77x1.5) for flows q_p 0.6, q_p 1.5 and q_p 2.5 m³/h. The compact design and the detachable integrator offer the best flexibility for difficult installation environments.

The **Supercal 739** can be used for the measurement of heating energy, cooling energy or a combination of heating / cooling energy in the temperature range of 5°C – 90°C. Through its two additional and optional pulse inputs, it's possible to connect, e.g. two water meters (hot and cold) and read them remotely via the heat meter.

Main features

- Easy to operate and read
- Non-volatile EEPROM memory
- 18 monthly values for heating energy, volume, cooling energy, the additional pulse inputs 1 and 2 and the set day values
- The **Supercal 739** is suitable for all communication environments:
 - Optical interface, M-Bus, powered over M-bus line, bi-directional radio, Wireless M-Bus (OMS compatible) and two pulses outputs
- Two pulses inputs
- Self-monitoring of conditions

Versions

The **Supercal 739** is available in the following versions:

- Flow meter from q_p 0.6 m³/h, q_p 1.5 m³/h, q_p 2.5 m³/h with
 - Single jet flow sensor
 - Coaxial multi-jet flow sensor with G2" thread
 - Coaxial multi-jet flow sensor with M77x1,5 thread
- **Default configuration:**
 - Heat meter MID, temperature sensors Ø 5 mm, 1.5m
 - Optical interface
 - Battery 6+1 years

Options Supercal 739

Temperature sensor Ø 5,2 mm, Ø 6 mm	■	■	■	■	■	■	■	■	■	■	■	■	■	■	■	■	■	■	■
Battery 12+1 years	■		■	■	■	■		■	■	■	■		■	■	■	■		■	■
M-Bus, power over M-Bus line		■					■					■					■		
Radio Supercom			■					■					■					■	
Wireless M-Bus (OMS)				■					■				■						■
2 Pulses outputs						*				*				°					°
2 Pulses inputs						■	■	■	■	■					■	■	■	■	■
Cooling or Heating / cooling												■	■	■	■	■	■	■	■

* Thermal version:

Heating energy and volume

° Heating / cooling version:

Heating and cooling energy

Functions

- Recording of heating energy or combined heating/cooling energy by means of measuring the flow and the temperature difference.
- Possibility to connect two additional pulse inputs
- Displaying consumption data:
 - Displaying 18 monthly energy and volume values
 - Displaying 18 monthly cooling energy
 - Displaying 18 monthly values of the additional pulse input 1
 - Displaying 18 monthly values of the additional pulse input 2
 - Set day values
 - Displaying operating data
 - Self-monitoring with error display

Flow sensor

Mechanical flow meter for flows q_p 0.6 m³/h, q_p 1.5 m³/h, q_p 2.5 m³/h and a temperature range from 5°C – 90°C with the following flow sensors :

- Single jet flow sensor
- Coaxial multi jet flow sensor with G2" thread
- Coaxial multi jet flow sensor with M77x1,5 thread

Temperature sensors

The pair of temperature sensors Pt 1'000 is connected to the integrator and is an integral part of the heat meter. By default the cold side sensor is mounted (and sealed) in the flow sensor. The temperature sensors mustn't be changed or modified.

Integrator

The integrator is equipped with a large 8-digits display and can be rotated by 360°. The integrator can be separated from the flow sensor and be installed separately. A cable of 0,6 meter connects the integrator to the flow sensor. The housing of the integrator got a protection degree of IP65 against dust and humidity.

Display

The LCD display of the **Supercal 739** has a large, clear design and high contrast, making it easy to read the data.

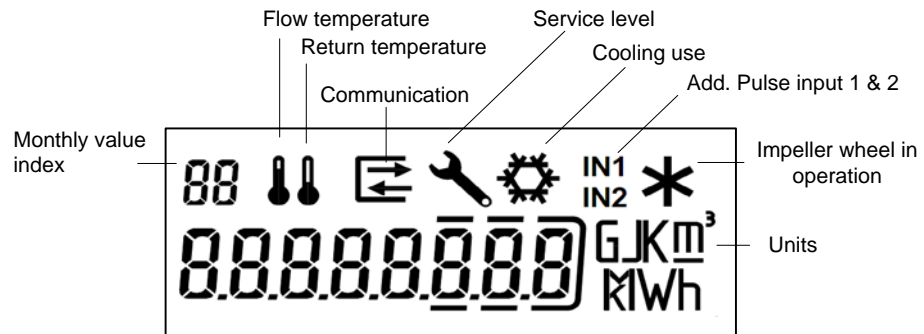

Display sequences

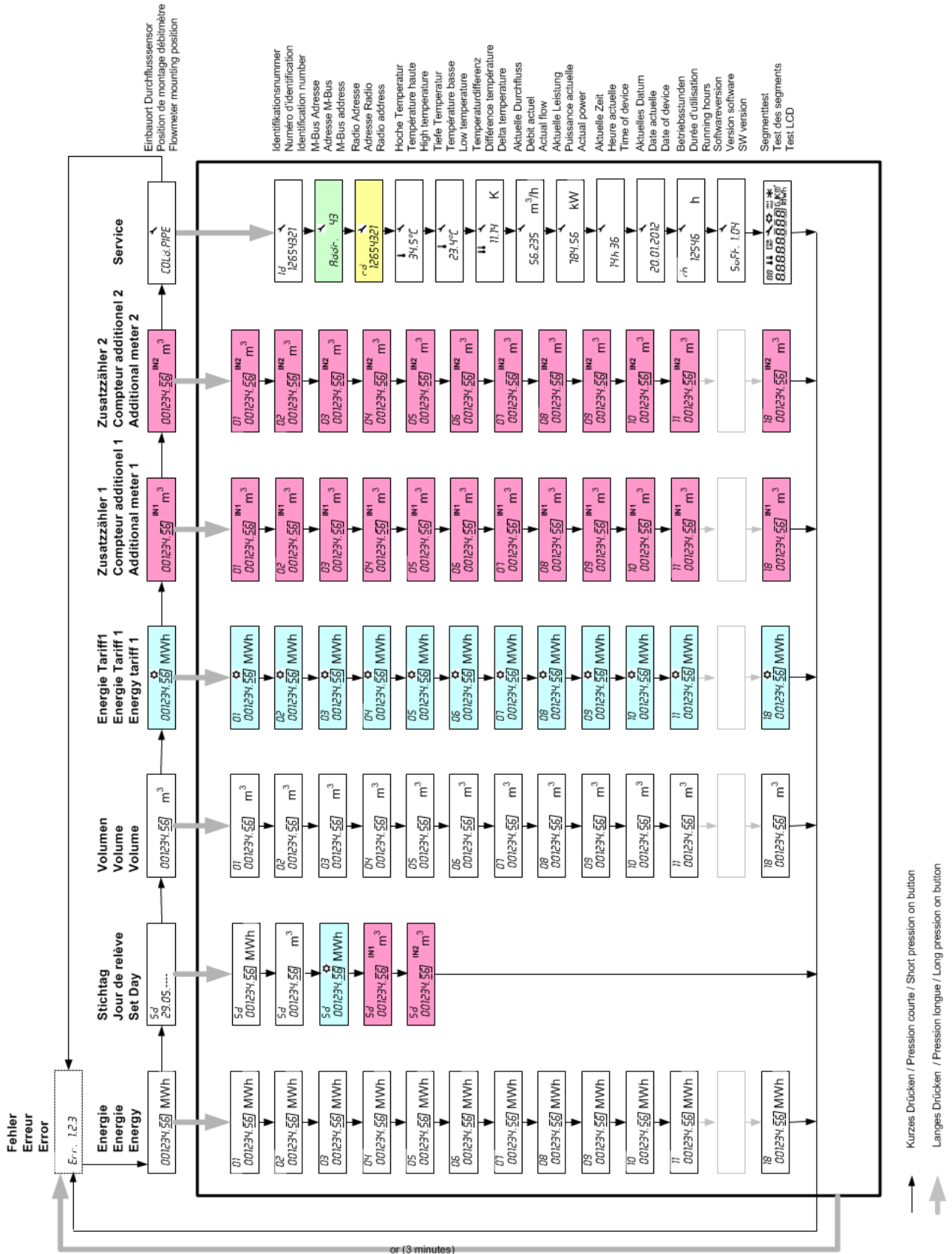

Error messages

Err 1	Flow higher than 1.2 x q _s or faulty flow sensor.
Err 2	Measured temperature out of range or faulty temperature sensor.

Measuring principle

The medium flowing through the system drives the impeller wheel and the rotational speed is scanned electronically using a magnet (single jet) or inductive (coaxial multiple jet) principle detection. The temperature difference in the supply and return line is measured with a pair of platinum temperature sensors (Pt 1'000).

Energy calculation

The flow sensor records the flow. Using a microprocessor, the integrator calculates the temperature difference and calculates the thermal energy, respectively the heating/cooling energy, consumed using the average flow and the heat coefficient.

Cooling energy

The cooling energy will be cumulated if the two following conditions are fulfilled:

- (Δt) Temperature difference > -0.5K
- Supply temperature < 18°C

The threshold value of the temperature is set by default at 18°C. If necessary, the threshold value can be incremented in steps of 1°C using the optical head. The cooling energy has the same physical unit as the heating energy. If the integrator is used for the combined heating/cooling measurement, the cooling energy, cooling power and the temperature difference are displayed with a minus sign (-) and the values will be stored in the Tariff 1 register.

Non-volatile memory

The device parameters, as well as the cumulative values for energy and volume, cooling energy, monthly values, set day values, values of the pulses input counters 1 and 2, operating hours and error type are stored in a non-volatile memory (EEPROM), where they are saved even in case of a power failure (e.g. changing batteries). Once per hour and in the event of battery failure, the cumulative values are updated in the EEPROM.

Monthly values

At the end of each month, the monthly values are stored. A total of 18 monthly values of heat energy, volume, cooling energy and of the additional pulses inputs 1 and 2 are memorized in the integrator.

Pulse inputs

As an option the **Supercal 739** offers the possibility to integrate beneficially up to two additional pulse inputs such as a hot and cold water meter.

Communication options

Several communication interfaces are available (see the options table). The configuration of the communication option of the **Supercal 739** can be carried out with the free software Prog739-749 available from Sontex.

TECHNICAL DATA SUPERCAL 739

Integrator

Temperature measurement

Temperature sensor 2 wires	Pt1'000
Diameter	Ø5.0; Ø5.2, Ø 6 mm
Cables length	1.5 m
Admissible range	0...110°C
Differential range	3...75 K
Response limit	0.5 K
Temperature resolution (display)	0.1 K
Temperature resolution Δt	0.01 K
Measurement cycle	from 10 seconds

Environment class

Environment class	C
Mechanics	M1
Electronics	E1
Battery protection class	III
Cable connection between flow sensor and integrator	0.6 m, fix
Protection index	IP 65

Permissible temperature range

Operation	5...55°C
Operation: radio version	5...40°C
Storage and transport	-10...60°C

Display

8-digits LCD

Display units

Energy	kWh, MWh, MJ, GJ
Volume	m ³
Additional pulse inputs:	Volume or pulses
Temperature	°C
Δ Temperature	K

Power supply

Lithium battery 3V	6+1 or 12+1 years
--------------------	-------------------

Pulse output

Open drain (MOS Transistor) $V_{CC_{max}} : 35 V_{DC} ; I_{CC_{max}} : 25 mA$	1 Hz, 500 ms
--	--------------

Pulse inputs with a dry contact

Power supply <small>internal</small>	2.3 V _{DC}
$R_{pull\ UP\ internal}$	2 M Ω
Protection	35 V _{DC}
Pulse factor	0...999.999 m ³ /lmp or without unit

Single Jet Flow Sensor

qp	Threaded connection		Mounting length mm	Mat.	PN	Maximal flow qs m ³ /h	Minimal flow qi l/h	Low flow threshold value (50°C) l/h	Threaded hole for sensor	Weight kg	Kvs value (20°C) m ³ /h	Pressure loss at qp bar
	G"	DN										
	(EN ISO 228-1)				bar	m ³ /h	l/h	l/h			m ³ /h	bar
0.6	3/4"	(15)	110	Br	16	1,2	12 / 24	3	Yes	0.8	1.2	0.25
1.0	3/4"	(15)	110	Br	16	2.0	10 / 20	3	Yes	0.9	2.1	0.23
1.5	3/4"	(15)	110	Br	16	3,0	15 / 30	3	Yes	0.9	3.1	0.23
1.5	1"	(20)	130	Br	16	3,0	15 / 30	3	Yes	1.0	3.1	0.23
2.5	1"	(20)	130	Br	16	5,0	25 / 50	8	Yes	1.1	5.2	0.23

*(h / v): Horizontal mounting / vertical mounting; Br: brass
16 bar = 1.6 MPa

Pressure loss curve

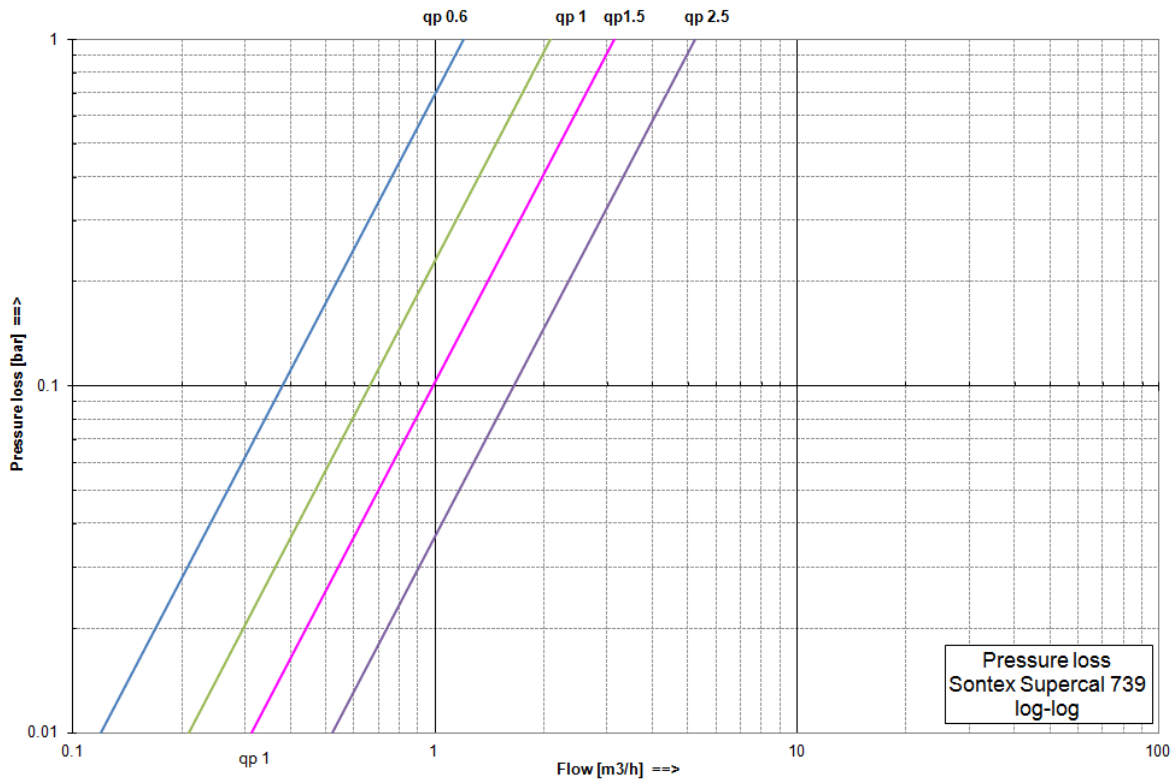

Metrological class

EN 1434 class 3

Mounting

Long term operating temperature

5°C - 90°C

Dimensions

Dimensions integrator

110.2 mm x 87.1 mm

Total Height

91.7 mm

Height from the axis of the tube

74.4 mm

Height without integrator

38.9 mm

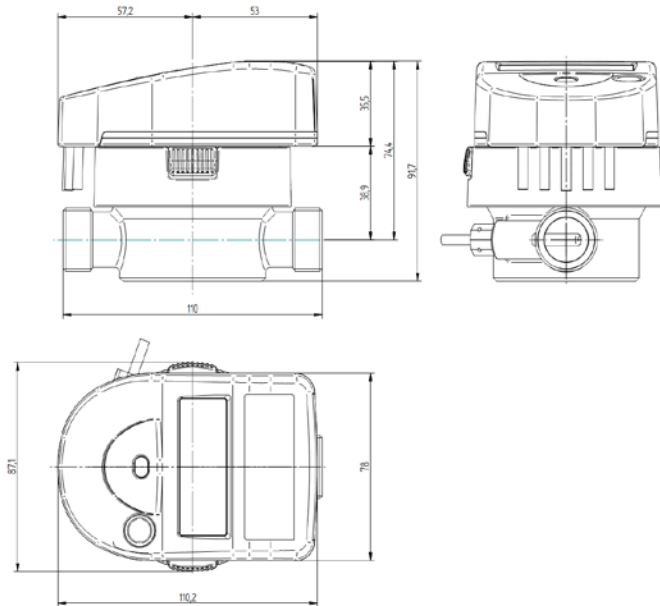

Coaxial Multiple Jet Flow Sensor with G2" connection

qp	Threaded connection		Mounting length	Mat.	PN	Maximal flow qs	Minimal flow qi	Low flow threshold value (50°C)	Threaded hole for sensor	Weight	Kvs value (20°C)	Pressure loss at qp
	m ³ /h	G"										
**0.6	(EN ISO 228-1)											
	3/4"	(15)	110	Br	16	1,2	12	8	Yes	0.6	1.7	0.13
1.5	3/4"	(15)	110	Br	16	3,0	15	10	Yes	0.6	3.4	0.19
1.5	1"	(20)	130	Br	16	3,0	15	10	Yes	0.6	3.4	0.19
**2.5	1"	(20)	130	Br	16	5,0	25	17	Yes	0.7	5.9	0.18

*EAS: base **in the pipeline; Br: brass
16 bar = 1.6 MPa

Pressure loss curve

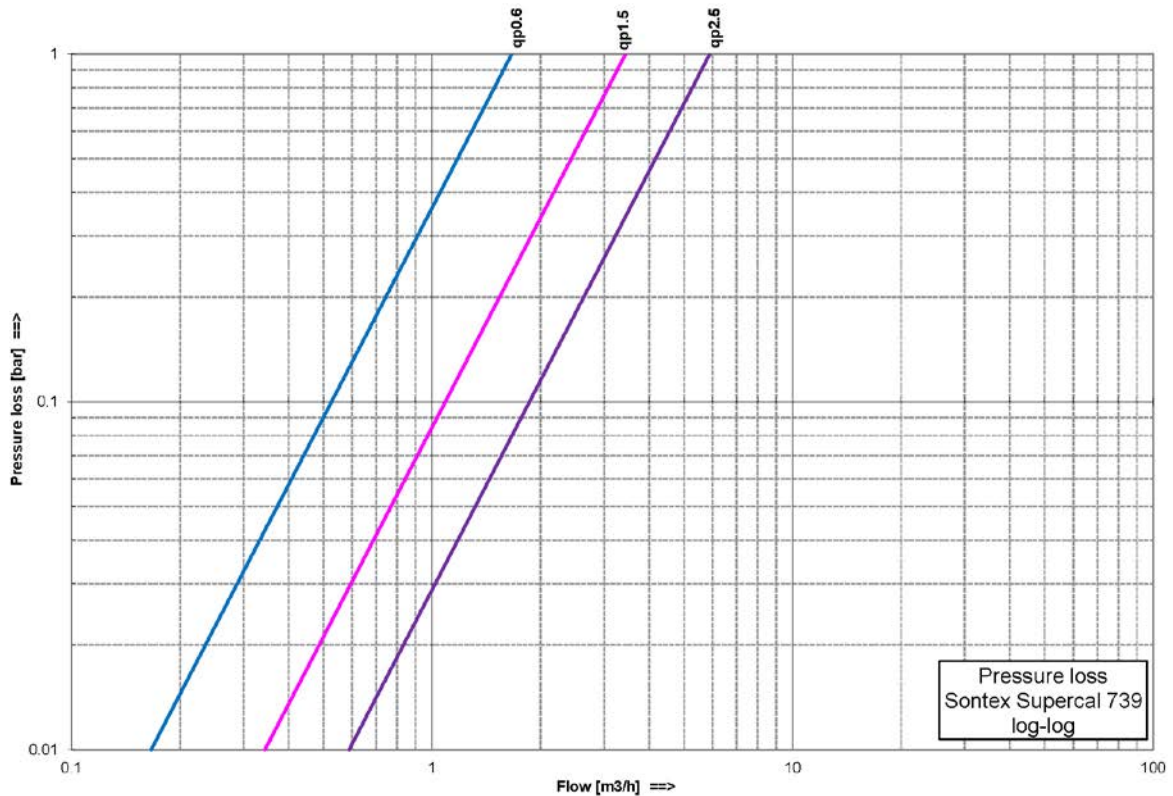

Metrological class

EN 1434 class 3

Mounting

External thread of the coaxial part
Long term operating temperature

G2"
5°C - 90°C

Dimensions

Dimensions integrator
Total height
Height from the base
Height without integrator

110.2 mm x 87.1 mm
90.6 mm
77.7 mm
42.2 mm

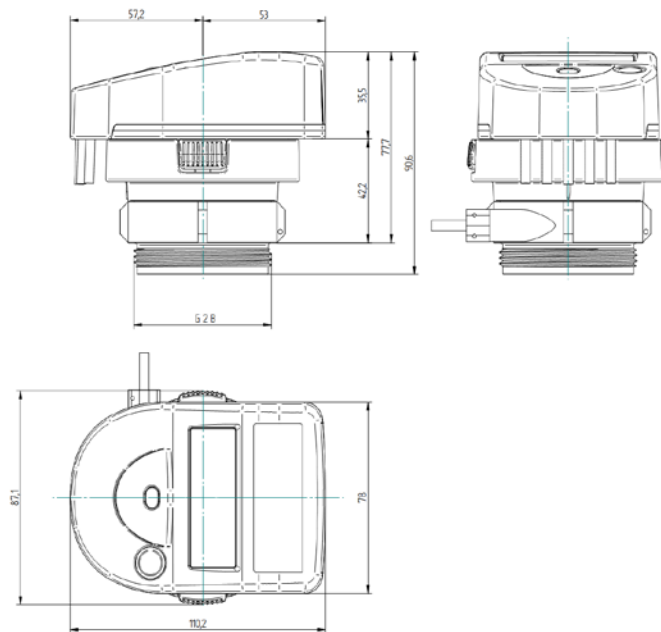

Coaxial Multiple Jet Flow Sensor with M77x1.5 connection

Flow metering

qp	Threaded connection		Mounting length	Mat.	PN	Maximal flow qs	Minimal flow qi	Low flow threshold value (50°C)	Threaded hole for sensor	Weight	Kvs value (20°C)	Pressure loss at qp
m ³ /h	G"	DN	mm		bar	m ³ /h	l/h	l/h		kg	m ³ /h	bar
**0.6	(EN ISO 228-1) 3/4"	(15)	110	Br	16	1,2	12	8	Yes	0.8	1.7	0.13
1.5	3/4"	(15)	110	Br	16	3,0	15	10	Yes	0.8	3.4	0.19
1.5	1"	(20)	130	Br	16	3,0	15	10	Yes	0.8	3.4	0.19
**2.5	1"	(20)	130	Br	16	5,0	25	17	Yes	0.9	5.2	0.23

*EAS: base **in the pipeline; Br: brass
16 bar = 1.6 MPa

Pressure loss curve

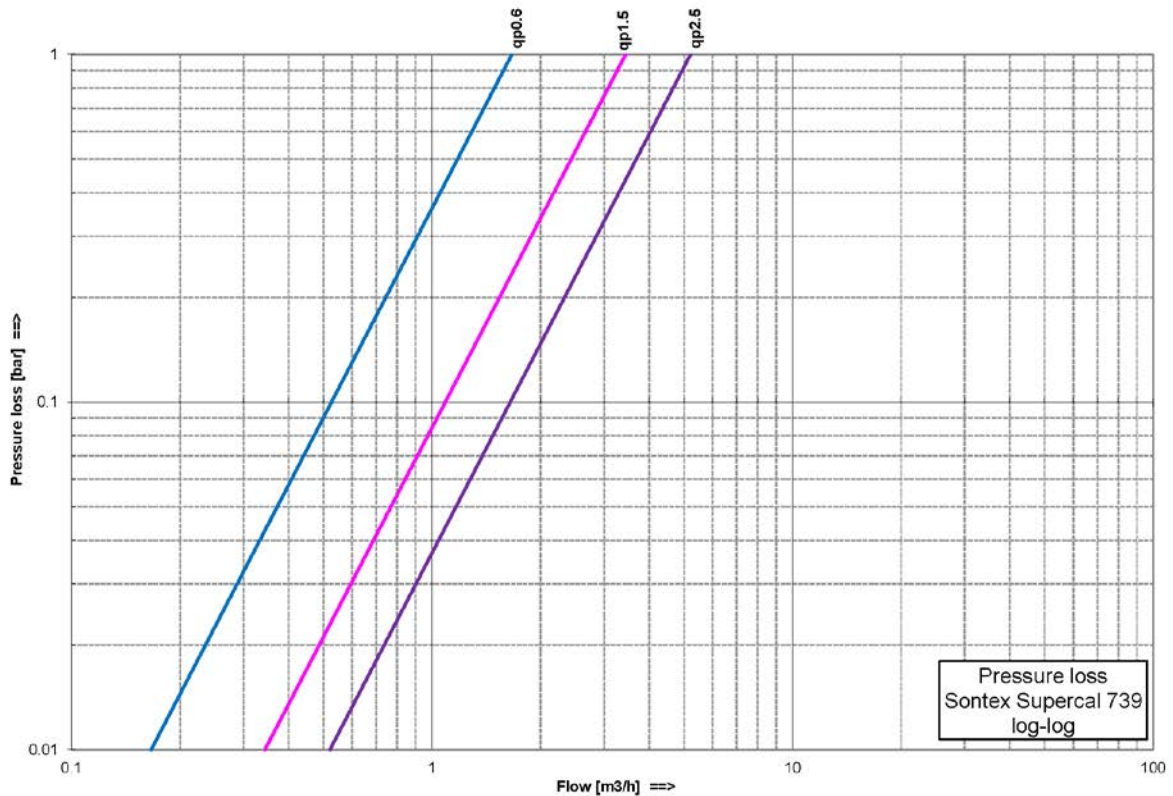

Metrological class

EN 1434 class 3

Mounting

External thread of the coaxial part M77x1.5
Long term operating temperature 5°C - 90°C

Dimensions

Dimensions integrator 110.2 mm x 87.1 mm
Total height 120.1 mm
Height from the middle of the base 106.1 mm
Height without integrator 70.6 mm

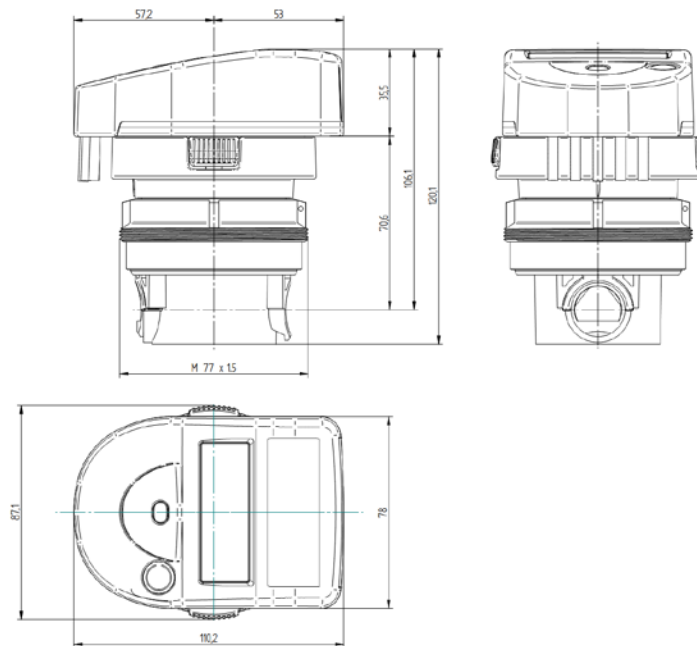

Technical support

For technical support, please contact your local Sontex representation or Sontex SA directly.

Hotline Sontex:

sontex@sontex.ch

+41 32 488 30 04

CE conformity according to

Directive 2004/22/EG (MID)

R &TTE guideline 1999/5/EC

Detailed declarations of conformity can be found on our homepage:

www.sontex.ch

Modifications subject to change without notice

Data Sheet Supercal 739 EN 25-03-2014

© Sontex SA 2013