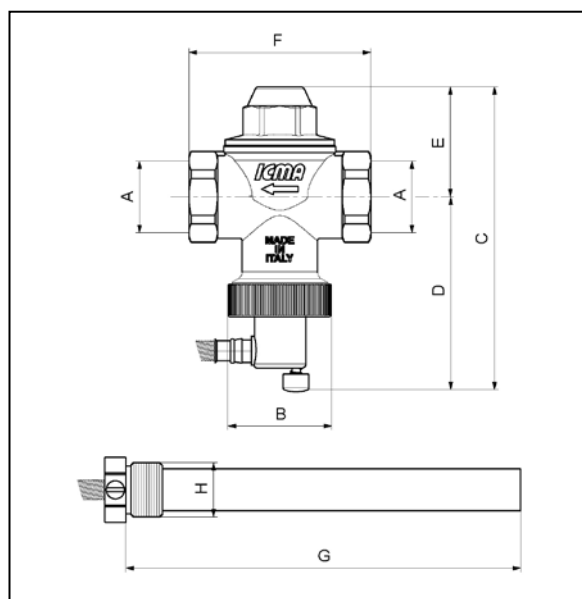

**FUNCTION**

The heat release safety valve is a device which limits the temperature of water in boilers fitted with a hot water tank or a heat exchanger.

When the temperature reaches 95° C the valve gradually opens, releasing hot water and letting cold water flow into the system to bring the temperature within safe limits.

The device complies with En14597 standards and may be used on systems that conform to En12828 standards applicable to boilers with power less than 100Kw.

**PRODUCTS AND SIZES****TECHNICAL FEATURES****CONNECTIONS**

Body	Female G 3/4"
Trap	Male G 1/2"
Capillary length	1300 mm

**MATERIALS USED**

Body	Brass CW617N UNI 12165
Control rod	Brass CW614N UNI 12164
Plug seal	EPDM
O-Ring	EPDM
Spring	Carbon steel C 70
Bellows support	Nylon Pa 66
Reset button	Nylon Pa 66

**PERFORMANCE**

Max operating pressure	10 bar
Temperature setting	95°C
Operating range	92 ÷ 112°C
Max sensor temperature	122° C
Fluid	Water
Max glycol percentage	50%
Release flow $\Delta p= 1\text{bar}$	3 m <sup>3</sup> /h
Ambient temperature range	0 ÷ 80°C

Code	A	B	C	D	E	F	G	H	Weight ( Kg)
90605AE05	3/4"	Ø40	119	76	43	70	152	1/2"	0.8

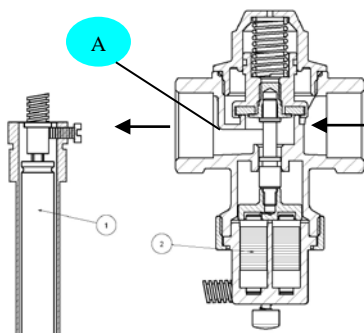
**OPERATING PRINCIPLE**

As the temperature of the water in the circuit increases, a liquid-gas phase change takes place inside the sensitive element (Point 1 in the figure), resulting in increased volume inside the capillaries and therefore dilatation of the bellows (Point 2), which press against the shutter and open passageway "A".

**NOTES ON MANUFACTURE**

To ensure maximum safety during operation, the valve contains two sensitive elements, each with its own separate circuit.

In the event that one element should malfunction, the other will in any case ensure that the valve works properly.

A red button on the lower part of the valve can be used to empty the system manually at any time.

## INSTALLATION

Before installing the safety valve please check that the system does not contain any impurities which might damage or obstruct the valve release seat.



An inspectable filter should be mounted on the incoming cold water line.

It is recommended that a pressure reducer be installed on the incoming line of the heating circuit, calibrated to the system operating pressure.

Check that the valve release capacity is compatible with the values specified by the boiler manufacturer.

The device must be installed by qualified technicians.

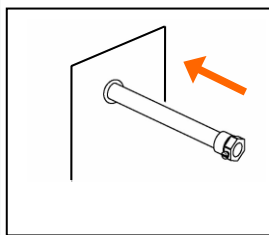

Mount the sensor holding trap on the upper part of the boiler or on the outgoing line, so that it comes before all on/off controls.

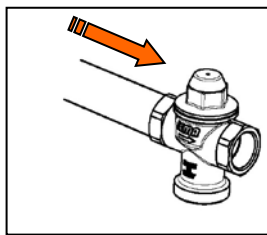

Mount the valve on the pipe, paying attention to the direction of flow shown by the "ARROW" on the body.

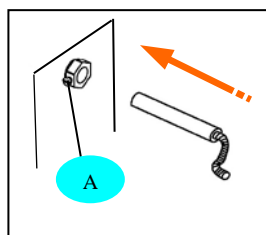

Insert the capillary in its trap, locking it with the screw (A).

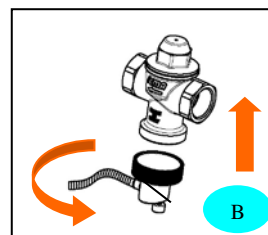

Put the sensor support cap in its housing, then tighten the textured ring (B) by hand.

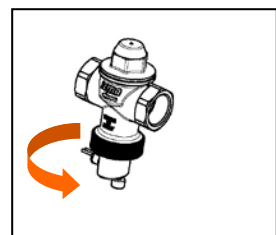

Turn the flexible sheath connecting up the probe by turning its cap. Now tighten the ring all the way.

## Installation diagram

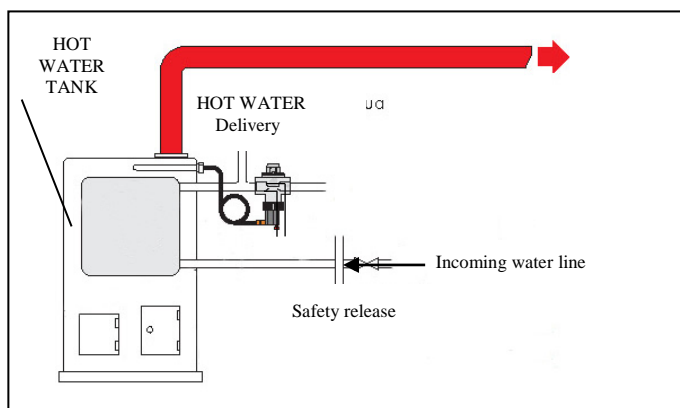

Example of safety release valve installed on a boiler with a built-in hot water tank.

## Connections - Maintenance

To ensure correct use of the component, connect up the outlet with an outlet diameter the same as the diameter of the valve (do not connect with a reducer).

The maximum distance from the heat generator must not exceed 2 metres, and there must be no more than 2 curves in the tube section.

There must be no upward sections in the drain pipe.

As shown in the picture (Fig. 1), there is a button in the lower part of the valve which releases water manually when pressed.

This must be done periodically (at least every time the system is started up again) to check that the device is working properly.

