

Lateral Connections

PA Saddle

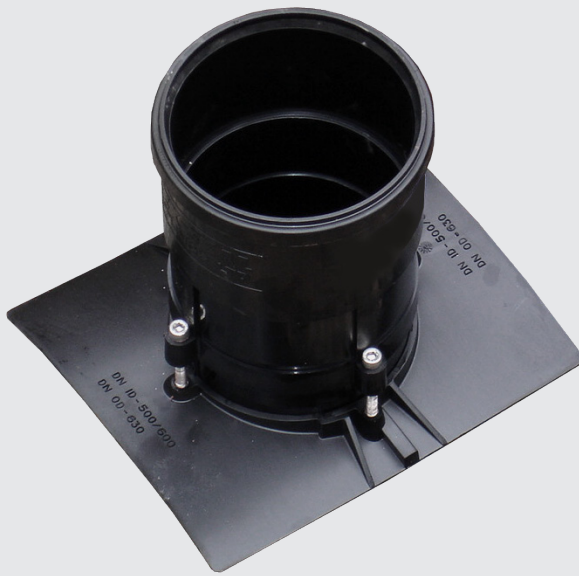

To connect a 160mm OD PVC lateral pipe into a twin wall or ribbed main pipe between DN300 and DN600.

Benefits

- Will withstand 0.5 bar internal pressure.
- No need to excavate around the pipe and disturb the pipe bedding.
- Materials are unaffected by normal ground conditions.

Suitable for...

- Highways
- Utilities
- Rail
- Agricultural
- etc.



Applications

This saddle range will cover ribbed sewer pipes from DN300 up to and including DN600. The PA1530UR is especially designed for DN300 Ultra-Rib pipe and incorporates a thinner rubber seal compared with the standard PA saddles. The saddles are generally suitable for the standard range of pipe wall thicknesses used by various pipe manufacturers.

For these saddles to function correctly the model chosen has to follow the pipe contour as closely as possible. Variations in wall thickness and pipe diameter can affect this.

For the correct saddle selection to be made, the following information is required about the main pipe:

- Either the pipe brand / manufacturer and nominal diameter; or
- Two of the following three dimensions:
 - Wall thickness;
 - Inside diameter;
 - Outside diameter.

Installation Instructions

1. Using a suitable holesaw, make a hole of 177mm (+2mm/-0.5mm) diameter in the wall of the pipe into which the adaptor is to be fitted. It is important that the hole is perpendicular to the pipe and that the holesaw is long enough to cut through the wall in one pass.
2. Remove any burring or flashing from the edges of the hole by lightly rubbing with abrasive paper. Wipe the inside surface clean.
3. With the adaptor removed from the packaging, apply lubricant to the outer face of the inner sleeve and seal in the area shown in fig. 1.
4. Insert the adaptor, as received, into the hole so that the saddle flange sits snugly onto the pipe OD.
5. Using the 'T' handled hexagon tool provided, turn screws 1 and 2 (see fig. 2) in a clockwise direction alternately by about 10 rotations at a time. This will draw the inner sleeve and bolt ring upwards. Continue turning the screws until the underside of the head touches the face of the bolt ring as shown in fig. 3. Repeat the procedure for screws 3 and 4. Ensure that the saddle flange remains on the pipe at all times.
6. The installation of the lateral adaptor is now complete.

Fig. 1

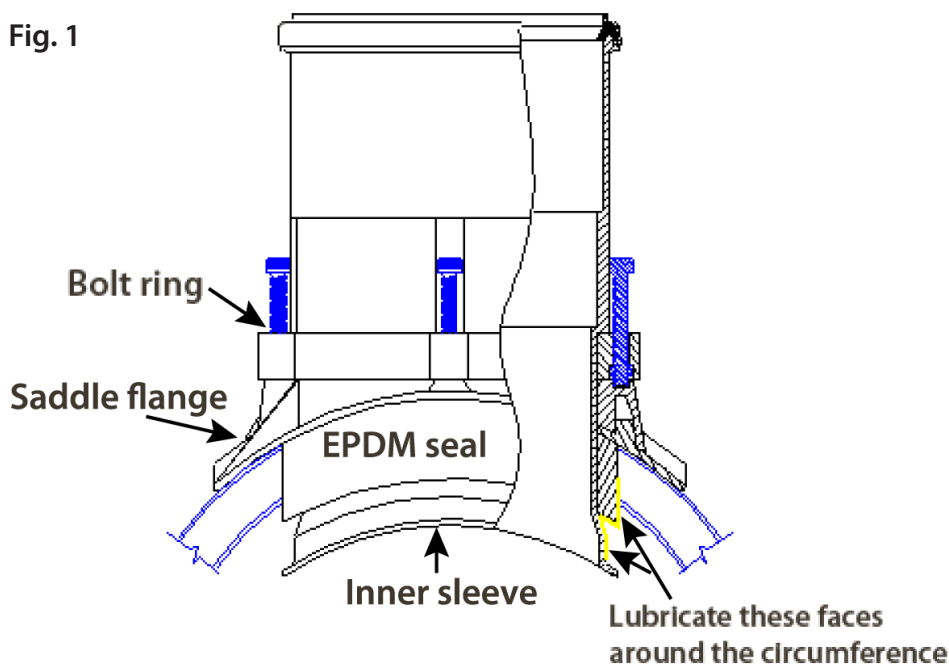

Fig. 2

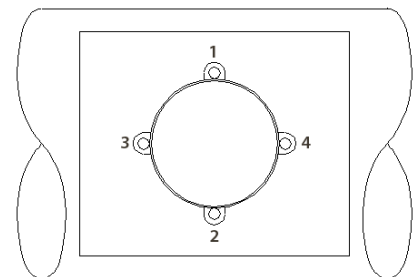

Fig. 3

